

Dear clients, thanks for choosing IBEST DS8 Series Multi-function Sensor Indicator! Before installing and operating the panel meters, please read this instruction manual carefully. For any questions, please contact our sales people immediately.

PREREAD INSTRUCTIONS

SAFETY CAUTIONS:

- Make sure the power is at "OFF" status before connecting the wires to avoid electric shock and strictly follow the connection diagram given out by the factory.
- Make sure the power OFF when cleaning the product.
- Working beyond the stated power supply (90-260V AC) is prohibited so as to avoid damage to the product or cause fire.
- Make sure the OUTPUT RELAY is used at the rated load and electrical life, if the contact of the output reply works against the electrical life, it may melt or burned or even cause fire.

INSTALLATION NOTICE:

- The product can not be installed outdoors, otherwise will shorten the operation life or cause electrical shock accidents.
- Ambient temperature: 0°C(32F) ~ 50°C(122F)
- Avoid to use the product in the such conditions as the dusty, flammable, explosive gas, vapor, water and oil spray environments.
- Prevent from strong surge & impact, high interference or other bad influences conditions.
- The product does not include a switch or fuse, if necessary, user needs to install by themselves, suggested spec. of fuse: rated voltage: 250V AC, rated current: 0.5A, with delay function.
- The output is active after the power ON for 10s, please consider this when configuring control loop.
- Safety devices must be configured when the product is used in the conditions such as nuclear energy control, medical treatment devices, autos, trains, aviation, entertainment...etc, for more details, please contact us.

1.FEATURES

- Multi-function sensor indicator, size:48H*96W*100Lmm.
- Universal input: TC, RTD, mA, mV, V(0~10V), Rt; Configurable by software. (Special signals: 0~5A and 20 segments of customized linear input.
- Up to 4 alarm relays, contact capacity: AC 250V/3A or DC 30V/3A (resistance load).
- Isolated analog output: 0~10mA or 4~20mA, configurable by software.
- Transmitter power supply: DC 24V or DC12V / 30mA max.
- RS485 or RS232 communication interface.
- Product power supply: AC 90~250V 50/60HZ, power consumption<5VA.
- Applications: DS8 series multi-function indicator can measure voltage/current signals of any ranges; can select data holding or peak value holding function; applied for 2-wire transformer, pressure sensor, 4-wire weighing sensor, remote pressure meter and other sensor measuring devices; for non-linear input, can provide 20 segments of customized linear process; can measure AC / DC voltage/

2.ORDERING CODE

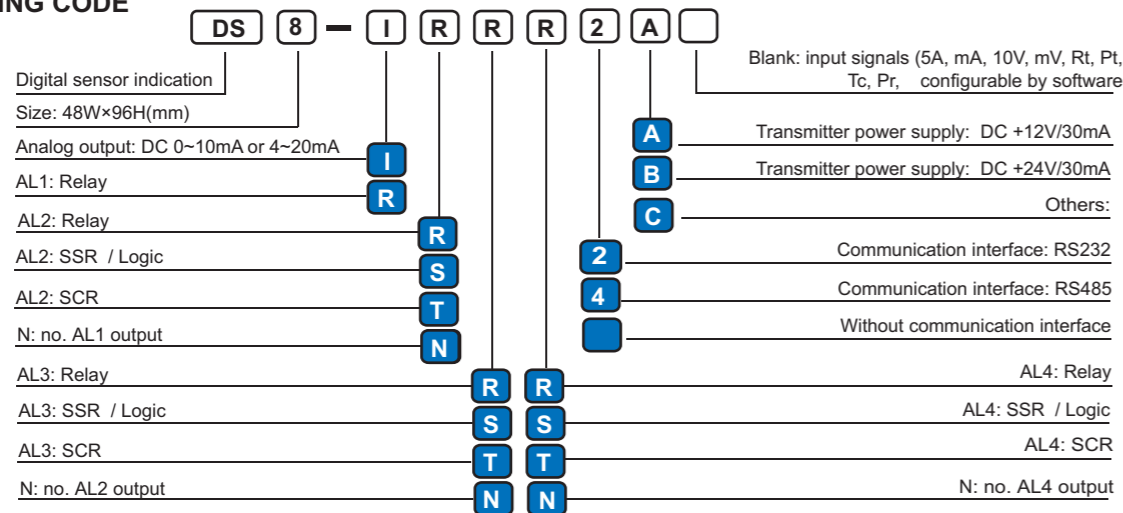

3. PANEL ILLUSTRATIONS



4. TECHNICAL SPECIFICATIONS & INPUT SIGNALS

Power supply:	90-260V AC 50/60HZ (+/- 10%)	INPUT TYPE	MEASURING RANGE	INPUT IMPEDANCE	SETTING
Power consumption:	≤ 5VA	A(AA/DA)	AC 0~5A (0~20A)	Special Signal	0~5A
Accuracy:	0.3% F.S ±2 digit (under normal conditions)	mA	4~20mA or 0~20mA	≤150Ω	4~20mA
Sampling rate:	<0.3s/time	V(AV/DV)	0~5V / 0~10V (0~500V)	≤200KΩ	0~10V
Input:	See input signals (right)	mV	0~10mV (± 100mV)	≤2MΩ	0~75mV
Alarm output:	Relay: NO., contact capacity: AC 250V /3A or DC 30V /3A Cosφ=1	Rt	0~400Ω / 0~10K	≤0.2mA	0~400Ω
Analog output:	4~20mA or 0~10mA, configurable by software	Pt	0~1K / 0~50K	≤0.1mA	
Transmitter supply:	Isolated DC 24V/30mA or DC 12V/30mA	TC	-200~650 °C	≤0.2mA	Pt100
Communication:	RS485 or RS232 interface (Modbus RTU protocol)	TC	Cu50/Cu100: -50~150 °C		
		TC	K: 0~1320°C		
		TC	J: 0~1300°C		
		TC	E: 0~1000°C		
		TC	T: -150~400.0°C		
		TC	B: 0~1820°C		
		TC	R: 0~1700°C		
		TC	S: 0~1600°C		
		Pr	20 segments customized linear input		Special Signal

Notice: 1, A input: factory setting is 0~5A, >5A is needed, please indicate when ordering.
 2, A input: factory setting is 0~10V, >10V is needed, please indicate when ordering.
 3, Rt input: factory setting is 0~400Ω, >400Ω is needed, please indicate when ordering.

5. ELECTRICAL CONNECTION DRAWING

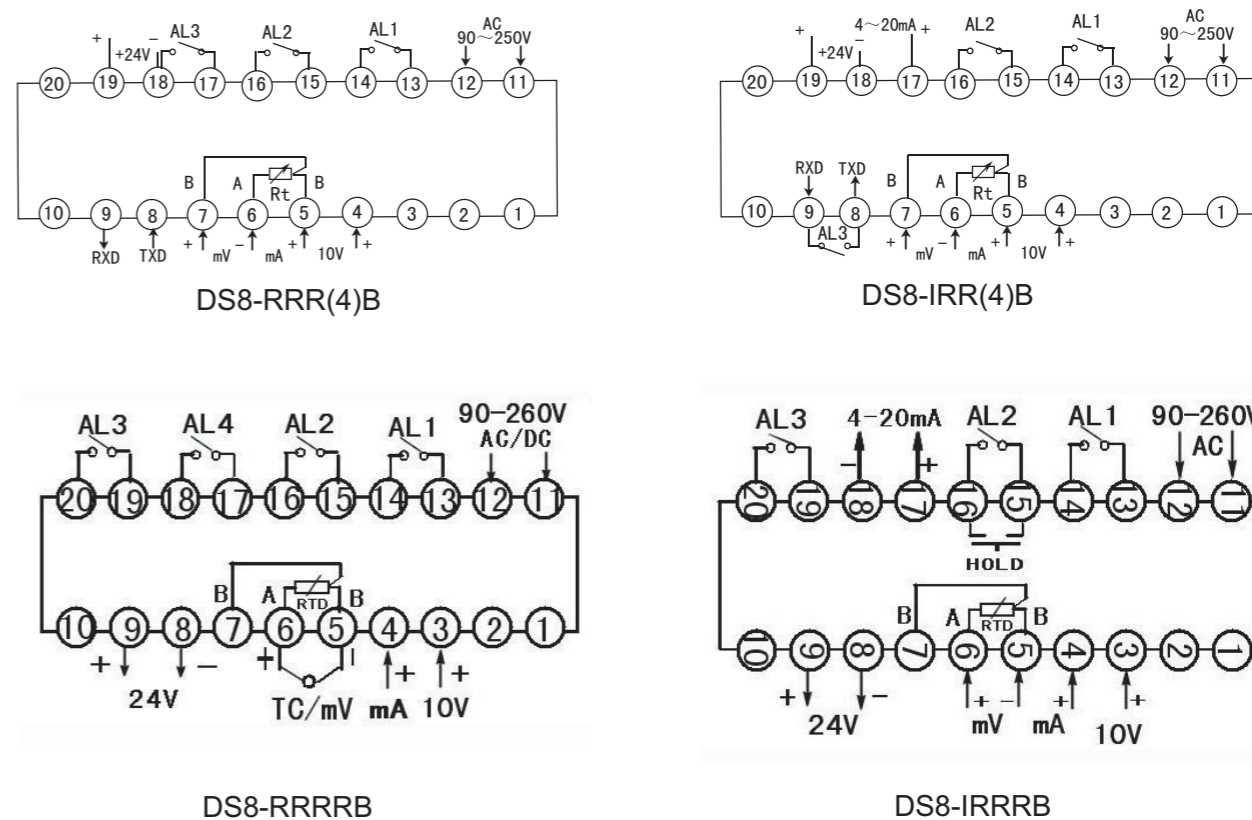

Note: if the connection drawing doesn't correspond to the drawing on the product, please according to the drawing on the product.

6 PANNEL DIMENSIONS AND INSTALLING HOLE DIMENSIONS

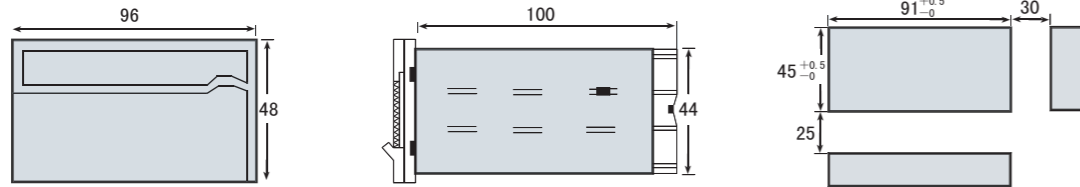

7.OPERATION INSTRUCTIONS:

- At the processing estate, press "SET" key once, the lower LED flashes, at this time, press " \wedge / " \vee key can modify the display ratio, factory setting=1.000. If request input=75mV and display=200A, the ratio should be set $200/75=2.666$. At the processing estate, press "<</RST" key >2s can clean out the zero point floating value.
- At the processing estate, press "Set" key > 3s to enter into the alarm mode setting menu. To modify the value, press "<</RST" key, the lower LED flashes, press " \wedge / " \vee to modify, at last press "Set" key to confirm the value modified. Press "Set" again to shift to the next parameter.
- In the alarm mode setting menu, select parameter "LCK", set LCK=0000, the parameters can read and write; set LCK=010, the second-grade menu parameters can read only.
- At the setting estate, no key operation within 25s will go back to the processing estate.

8.PARAMETERS MENU:

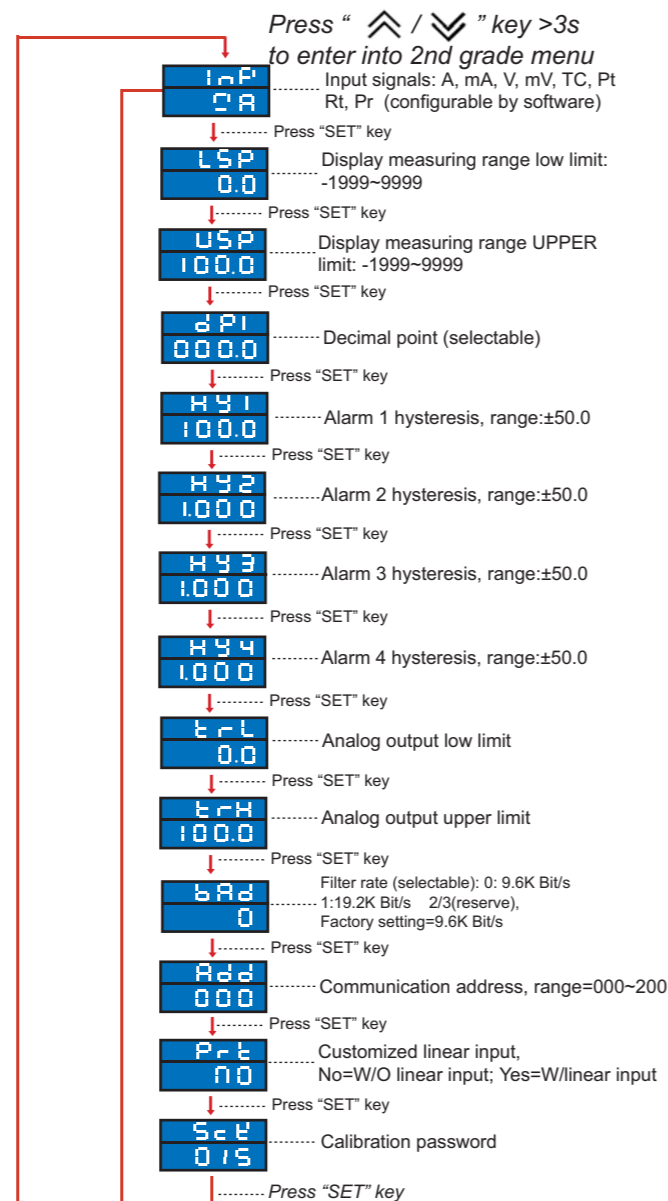
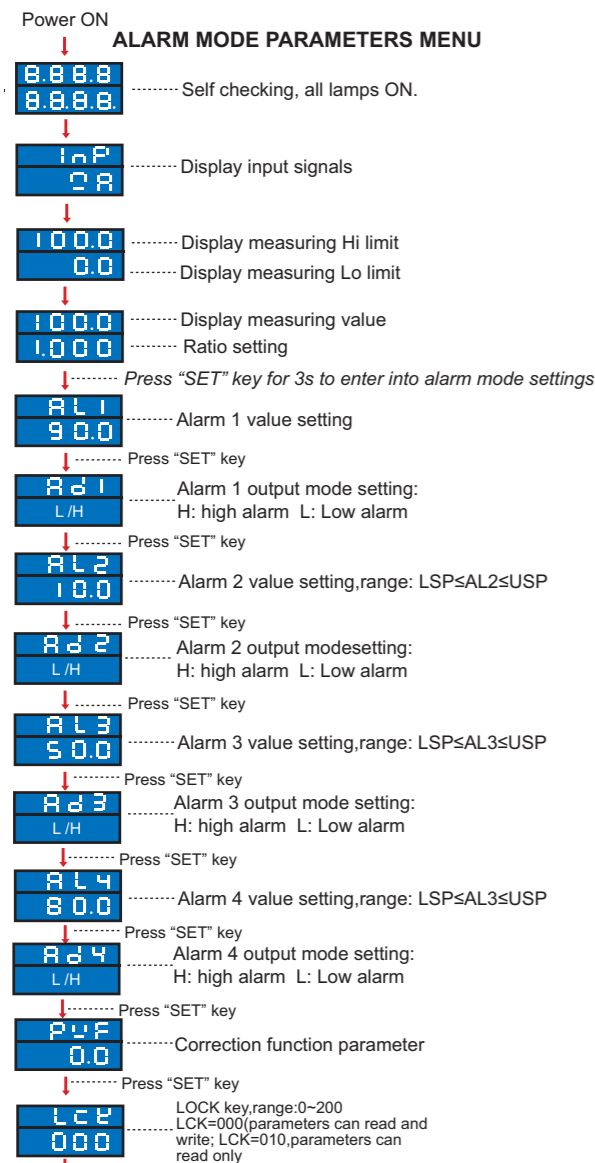

9.Application examples:

- Application with 2-wire pressure sensor: request auxiliary supply "DC 24V/30mA " and with isolated analog 4~20mA output: please refo page 4 F1
- Application with resistance variable pressure sensor, request auxiliary supply "DC 12/30mA " , output 2mV/V, and connect with PC: please refo page 4 F2

10.Product maintenance notice:

- The instrument should be power ON for 15 minutes before operating.
- The instrument ambient temperature is 0~50°C; relative humidity: 85%
- The instrument calibration period is 12 months.
- Avoid shock and impact, prevent operation from heavy dust and poisonous chemical materia medica & gas environment.
- If the input signals have high-frequency interference, the wires must configure a high-frequency filter.
- The input wires should not be too long. If the distance between the signal input terminal and the product can not be shortened, please use shielded twisted-pair cable and the shielded layer connected with the signal low end.
- Keep from the direct sunlight, stock temperature is -10~70°C/60%(RH). Do not contact the organic solvent and oil.
- To stock in long terms without operation, please connect to power ever 3 months for min. 4 hours each time.

11.Others:

- The complete product contains: product with connection diagram, instruction manual, installing brackets (1 set), inspection QC lable and packing box with product label.
- Guarantee: any defected products under normal operation within 12 months can be returned and replaced by us. Damage by user's wrong operation can not be returned; In case repair is necessary, buyer should take charge of the freight fee, on condition large quantities need to be repaired, repair fee should be considered

